

Tornio a fantina mobile Star SV32

INFORMAZIONI DI BASE:

Codice	48E490
Nome prodotto	Tornio a fantina mobile Star SV32
Categoria	Tornitura/Torni cnc a fantina mobile
Marca e modello	Star SV32
Anno costruzione	2003

SPECIFICHE TECNICHE:

Modello CNC	Fanuc
Versione del CNC	16i - TB
Potenza mandrino principale	7,5 Kw
Passaggio barra mandrino principale	32 mm
Corsa fantina (Z1)	310 mm
Numero Giri mandrino principale	7000
Numero assi lineari	7
Numero posti utensili fissi piastra portautensili	5
Numero posti utensili motorizzati piastra portautensili	3
Alta pressione refrigerante	si
Numero torrette/slitte porta utensili	1
Numero posti utensili prima torretta/slitte	10
Numero Motorizzati prima torretta/slitte	10
Contromandrino	si
Numero Giri contromandrino	7000
Potenza contro mandrino	3,7 Kw
Passaggio barra	32 mm

INDUSTRIALBUYER

Corsa Z contromandrino	150 mm
Refrigerante utilizzato	olio intero
Modello e marca caricatore di barre	lemca Boss 432
Evacuatore truciolo	a tappeto

DIMENSIONI E PESO:

Lunghezza	2645 mm
Larghezza	1403 mm
Altezza	1680 mm
Peso	3880 Kg

Foto integrale macchina



Foto zona di lavoro



Foto pannello di controllo



Foto facoltativa 1

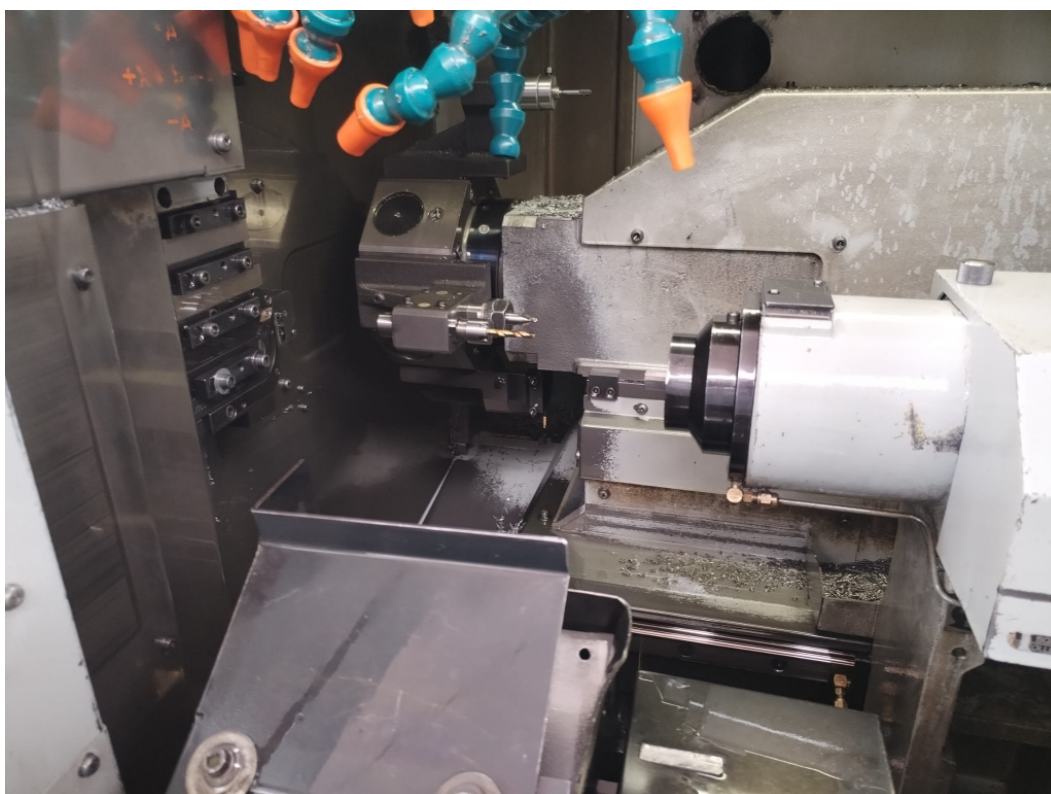

Foto facoltativa 2



Foto facoltativa 3



Foto facoltativa 4

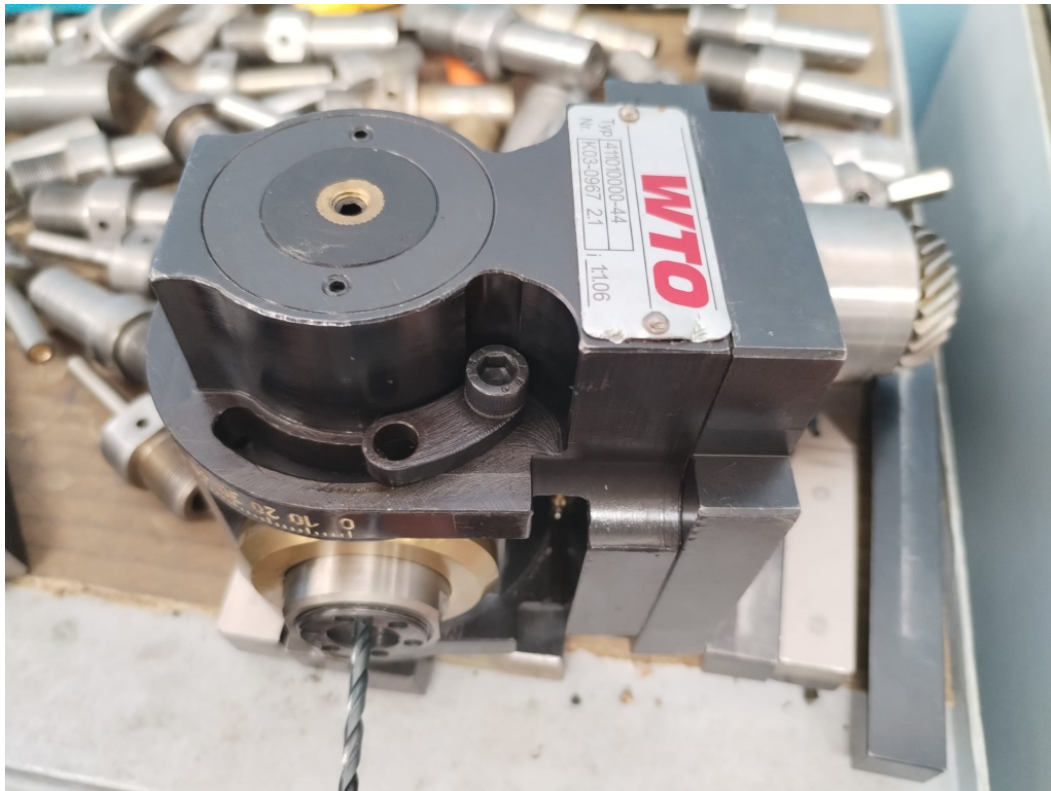

Foto facoltativa 5

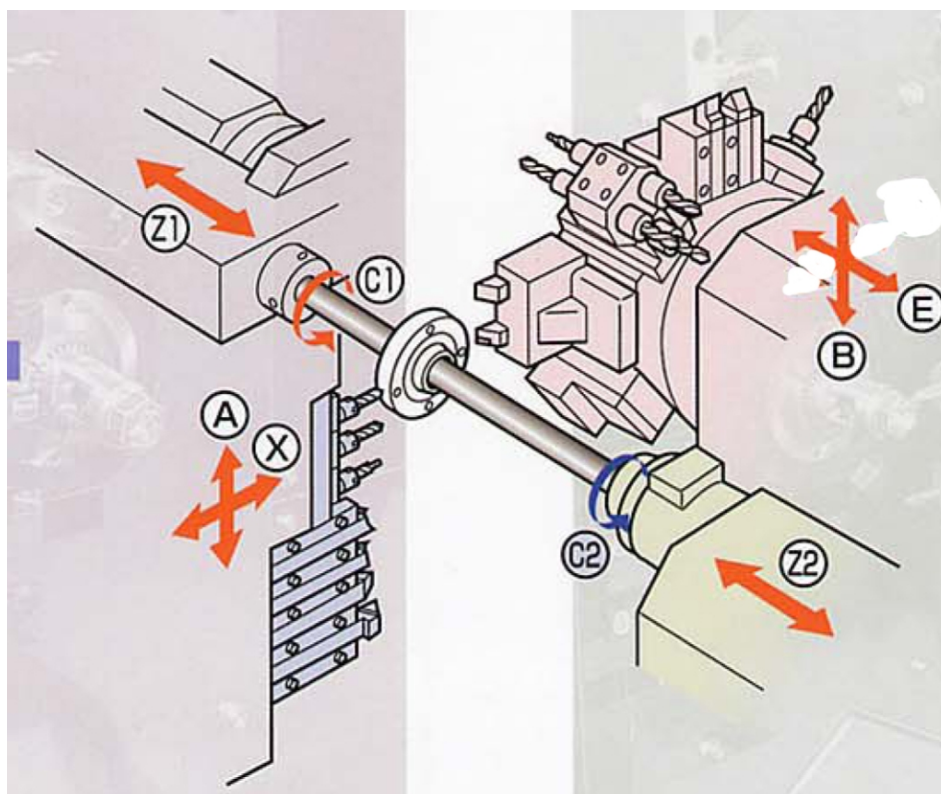

INDUSTRIALBUYER

DATI VENDITORE



David Rota



info@industrialbuyer.it



3479818206



<https://www.messenger.com/t/industrialbuyer.it>



<https://www.linkedin.com/in/industrialbuyer/>
