

Tornio a fantina mobile Nexturn NST56

INFORMAZIONI DI BASE:

Codice	B5A2E2
Nome prodotto	Tornio a fantina mobile Nexturn NST56
Categoria	Tornitura/Torni cnc a fantina mobile
Marca e modello	Nexturn NST56
Anno costruzione	2012

SPECIFICHE TECNICHE:

Modello CNC	Fanuc
Versione del CNC	31i - B
Potenza mandrino principale	15 Kw
Passaggio barra mandrino principale	56 mm
Corsa fantina (Z1)	150 mm
Numero Giri mandrino principale	5000
Fantina fissa	si
Numero assi lineari	9
Numero posti utensili fissi piastra portautensili	5
Numero posti utensili motorizzati piastra portautensili	5
Avanzamenti rapidi assi lineari X Y Z	24 m/min
Numero torrette/slitta porta utensili	1
Numero posti utensili prima torretta/slitta	12
Numero Motorizzati prima torretta/slitta	12
Numero utensili posteriori fissi	4
Numero utensili posteriori motorizzati	3
Refrigerante utilizzato	olio intero

Evacuatore truciolo	a tappeto
----------------------------	-----------

DIMENSIONI E PESO:

Lunghezza	2850 mm
------------------	---------

Larghezza	1760 mm
------------------	---------

Altezza	1950 mm
----------------	---------

Peso	6400 Kg
-------------	---------

Foto integrale macchina



Foto zona di lavoro



Foto pannello di controllo



Foto facoltativa 1



Foto facoltativa 2



Foto facoltativa 3



Foto facoltativa 4



Foto facoltativa 5

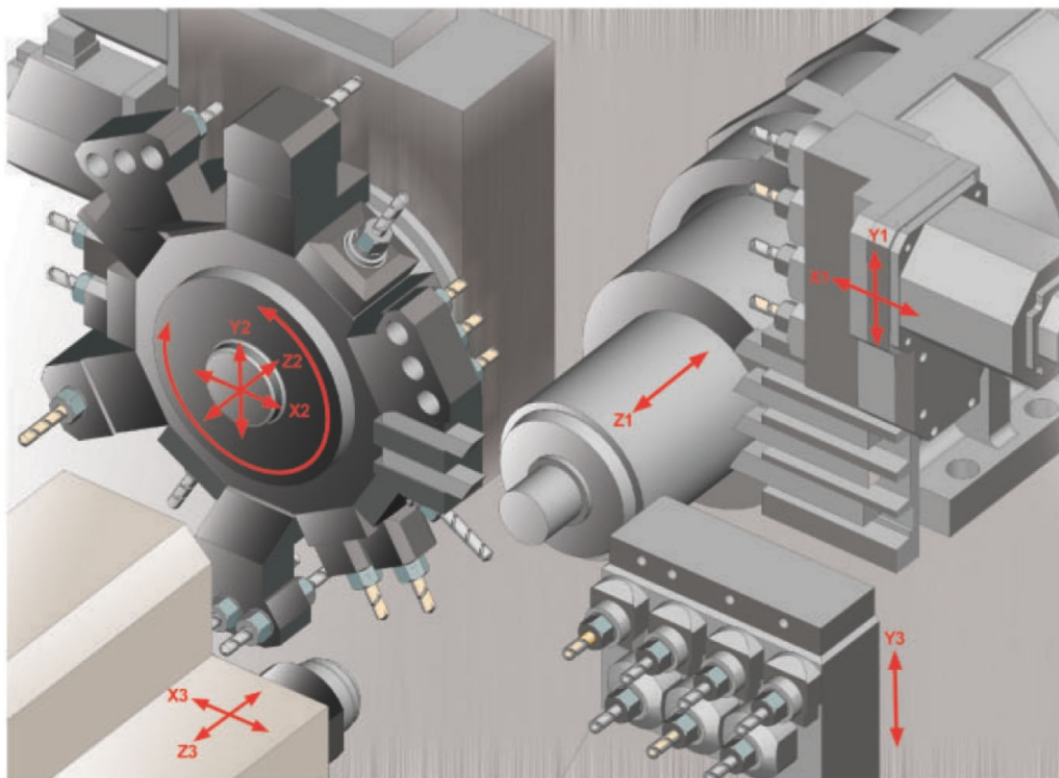

INDUSTRIALBUYER

DATI VENDITORE



David Rota



info@industrialbuyer.it



3479818206



<https://www.messenger.com/t/industrialbuyer.it>



<https://www.linkedin.com/in/industrialbuyer/>
