

## Tornio a fantina mobile Tornos Deco 13 Basic

### INFORMAZIONI DI BASE:

<b>Codice</b>	10216A
<b>Nome prodotto</b>	Tornio a fantina mobile Tornos Deco 13 Basic
<b>Categoria</b>	Tornitura/Torni cnc a fantina mobile
<b>Marca e modello</b>	Tornos Deco 13 Basic
<b>Anno costruzione</b>	2001

### SPECIFICHE TECNICHE:

<b>Modello CNC</b>	Fanuc
<b>Versione del CNC</b>	PNC DECO
<b>Potenza mandrino principale</b>	3,7 Kw
<b>Passaggio barra mandrino principale</b>	16 mm
<b>Corsa fantina (Z1)</b>	160 mm
<b>Numero Giri mandrino principale</b>	12000
<b>Numero assi lineari</b>	6
<b>Numero posti utensili fissi piastra portautensili</b>	5
<b>Numero posti utensili motorizzati piastra portautensili</b>	3
<b>Alta pressione refrigerante</b>	si
<b>Contromandrino</b>	si
<b>Numero Giri contromandrino</b>	12000
<b>Potenza contro mandrino</b>	2,2 Kw
<b>Passaggio barra</b>	16 mm
<b>Numero utensili posteriori fissi</b>	3
<b>Refrigerante utilizzato</b>	olio intero
<b>Modello e marca caricatore di barre</b>	Iemca Genius 118

### DIMENSIONI E PESO:

# INDUSTRIALBUYER

<b>Lunghezza</b>	2950 mm
<b>Larghezza</b>	1100 mm
<b>Altezza</b>	2300 mm
<b>Peso</b>	3000 Kg

Foto integrale macchina



Foto zona di lavoro



Foto pannello di controllo



Foto facoltativa 1

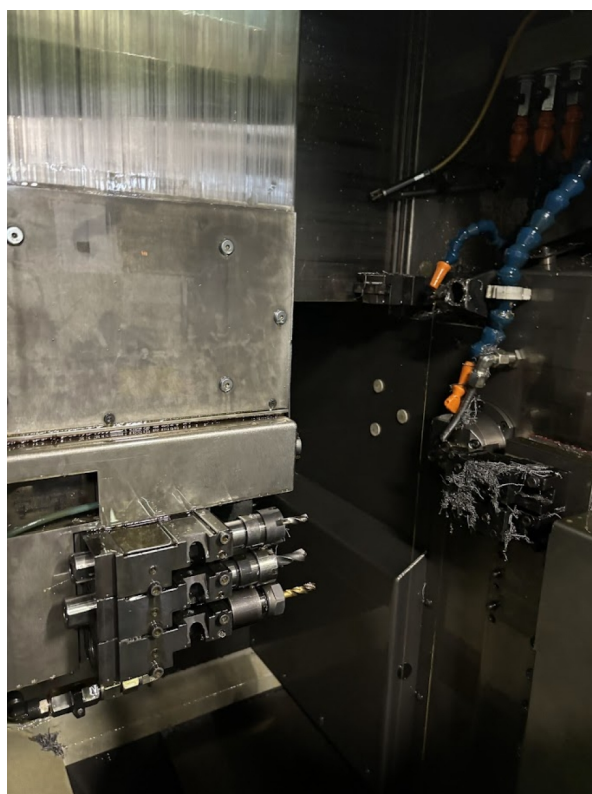

Foto facoltativa 2



Foto facoltativa 3



Foto facoltativa 4



# INDUSTRIALBUYER

---

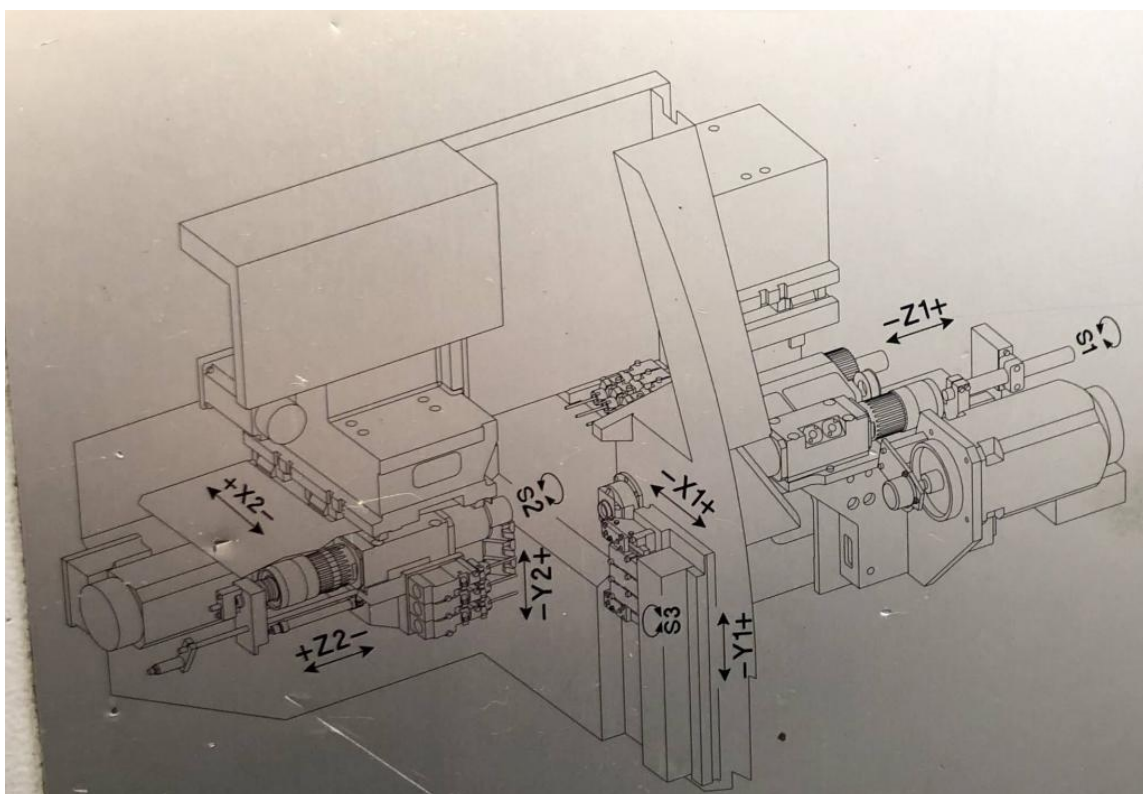
## DATI VENDITORE



David Rota



[info@industrialbuyer.it](mailto:info@industrialbuyer.it)



3479818206



<https://www.messenger.com/t/industrialbuyer.it>



<https://www.linkedin.com/in/industrialbuyer/>

---