

## Tornio a fantina mobile Citizen L20X

### INFORMAZIONI DI BASE:

<b>Codice</b>	80E672
<b>Nome prodotto</b>	Tornio a fantina mobile Citizen L20X
<b>Categoria</b>	Tornitura/Torni cnc a fantina mobile
<b>Marca e modello</b>	Citizen L20X
<b>Anno costruzione</b>	2019

### SPECIFICHE TECNICHE:

<b>Modello CNC</b>	Mitsubishi
<b>Potenza mandrino principale</b>	3,7 Kw
<b>Passaggio barra mandrino principale</b>	20 mm
<b>Corsa fantina (Z1)</b>	200 mm
<b>Numero Giri mandrino principale</b>	10000
<b>Numero posti utensili fissi piastra portautensili</b>	5
<b>Numero posti utensili motorizzati piastra portautensili</b>	3+4
<b>Avanzamenti rapidi assi lineari X Y Z</b>	32 m/min
<b>Alta pressione refrigerante</b>	si
<b>Valore pressione</b>	70 bar
<b>Contromandrino</b>	si
<b>Numero Giri contromandrino</b>	8000
<b>Potenza contro mandrino</b>	1,5 Kw
<b>Passaggio barra</b>	20 mm
<b>Utensili frontali fissi contromandrino</b>	6
<b>Numero utensili posteriori motorizzati</b>	8
<b>Refrigerante utilizzato</b>	olio intero

# INDUSTRIALBUYER

<b>Modello e marca caricatore di barre</b>	lemca
<b>Evacuatore truciolo</b>	a tappeto

## **DIMENSIONI E PESO:**

<b>Lunghezza</b>	2110 mm
<b>Larghezza</b>	1115 mm
<b>Altezza</b>	1835 mm
<b>Peso</b>	2500 Kg

**Foto integrale macchina**



**Foto zona di lavoro**

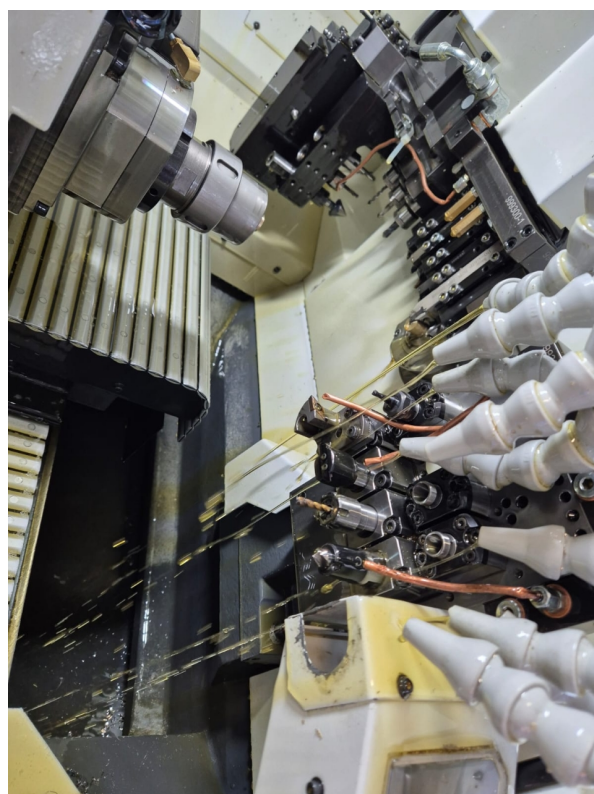

**Foto pannello di controllo**



**Foto facoltativa 1**

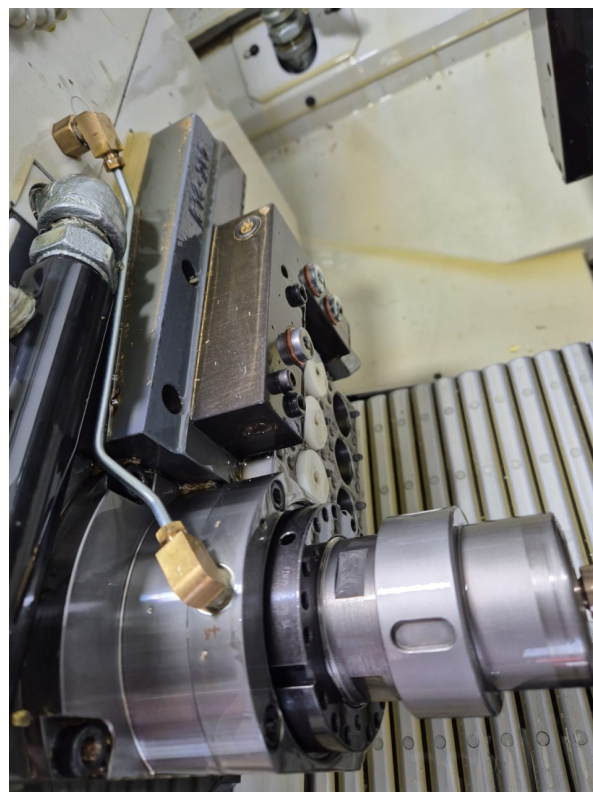

**Foto facoltativa 2**



**Foto facoltativa 3**



Foto facoltativa 4



Foto facoltativa 5



# INDUSTRIALBUYER

---

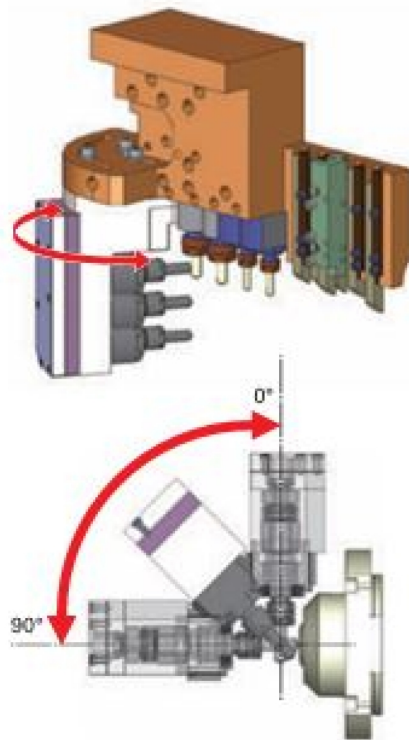
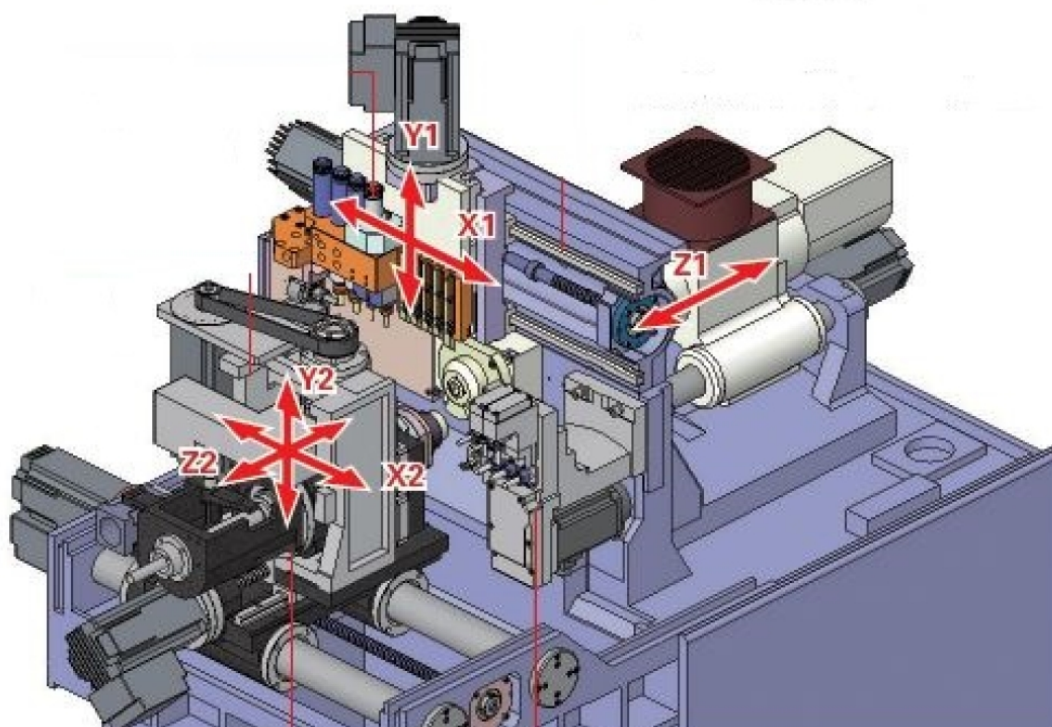
## DATI VENDITORE



David Rota



[info@industrialbuyer.it](mailto:info@industrialbuyer.it)



3479818206



<https://www.messenger.com/t/industrialbuyer.it>



<https://www.linkedin.com/in/industrialbuyer/>

---